

A1		
Q.TA' 2	ZINCATO	S275JR

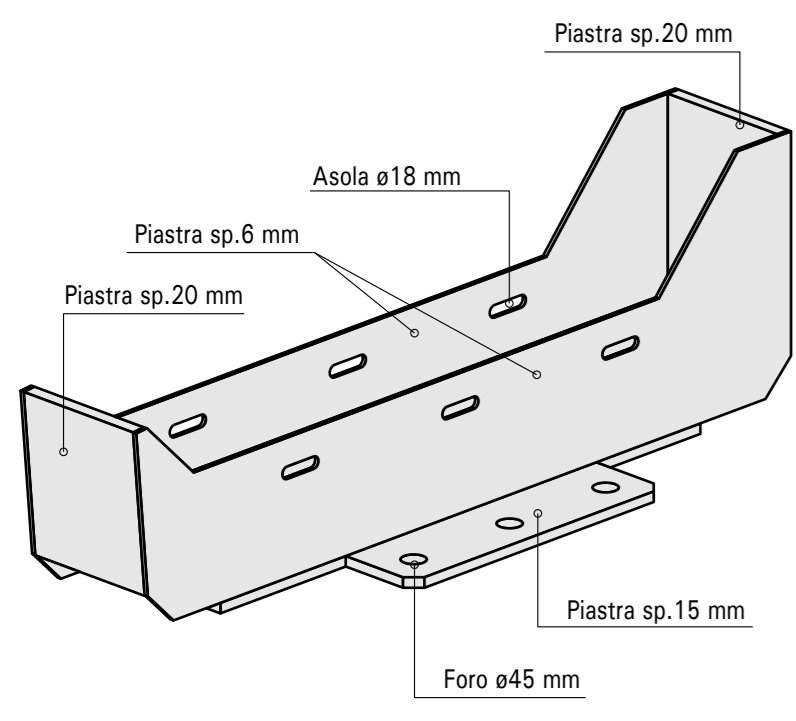

A2-DX		
Q.TA' 8	ZINCATO	S275JR

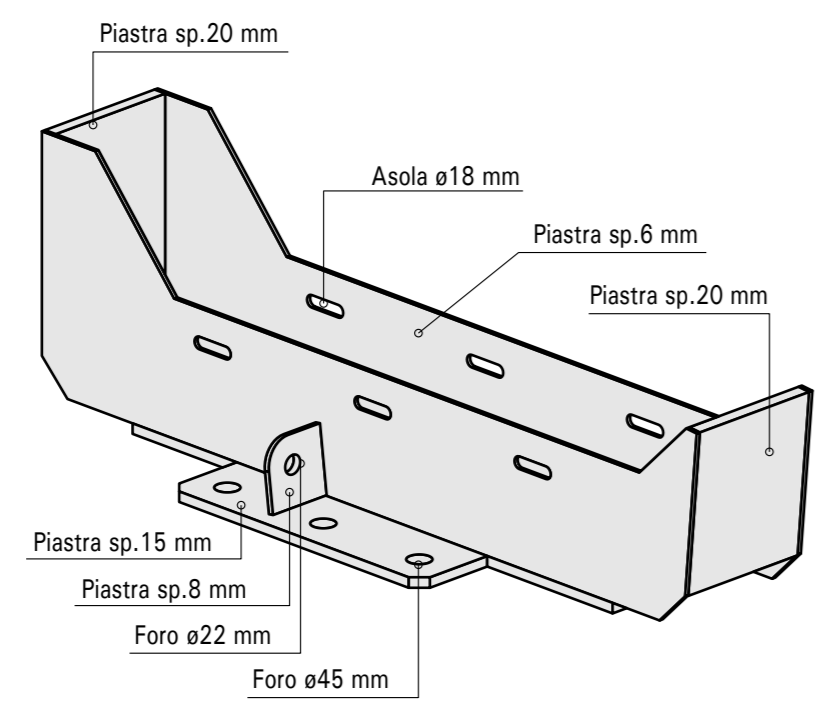

A2-SX		
Q.TA' 8	ZINCATO	S275JR

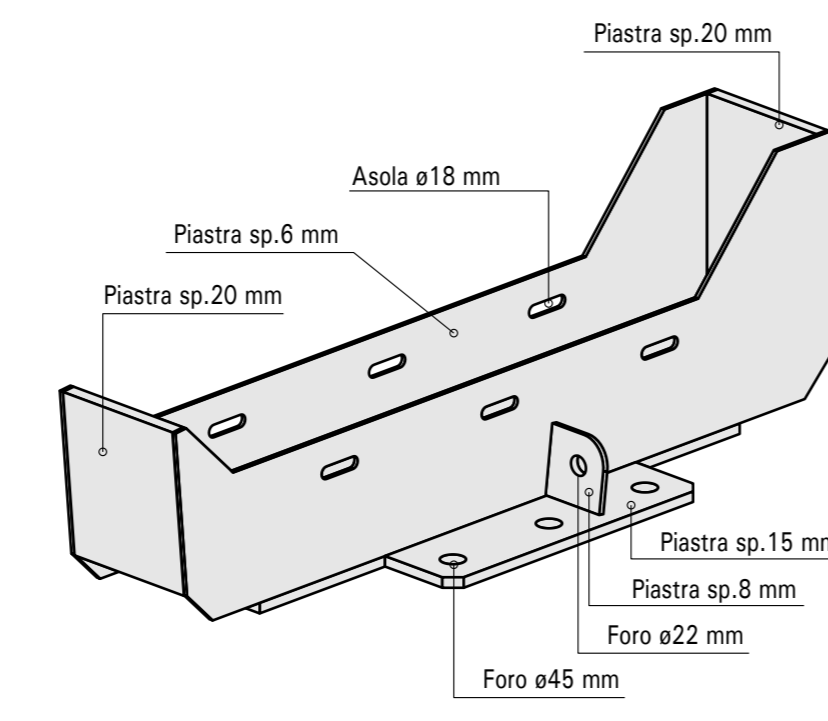

A3-DX		
Q.TA' 2	ZINCATO	S275JR

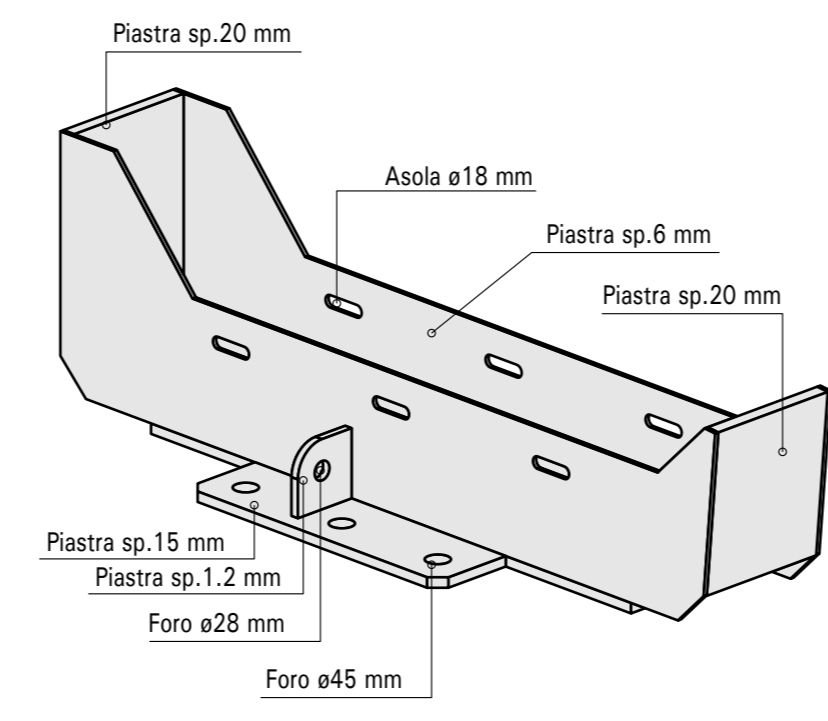

A3-SX		
Q.TA' 2	ZINCATO	S275JR

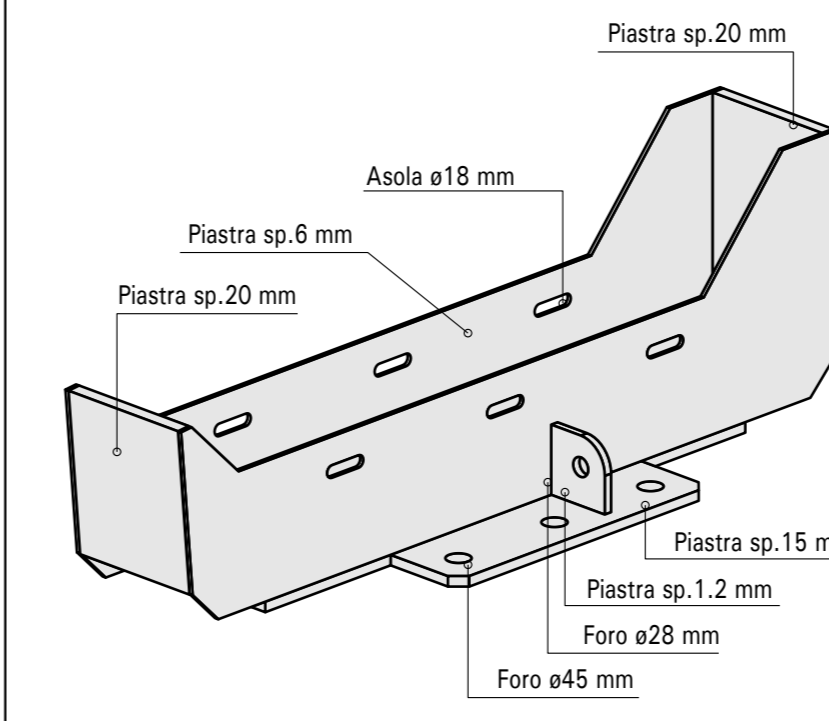

A4		
Q.TA' 22	ZINCATO	S275JR

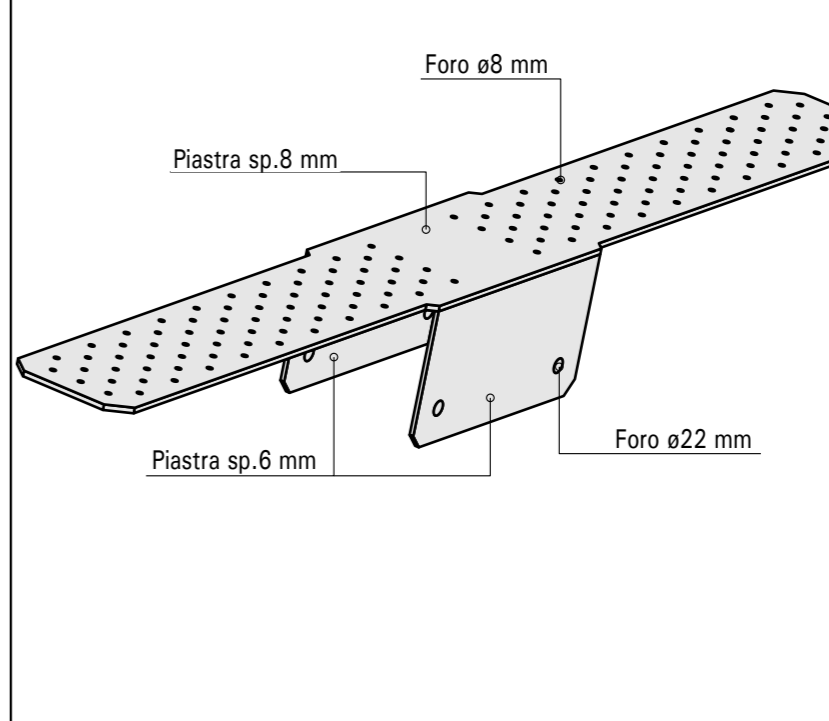

A5		
Q.TA' 22	ZINCATO	S275JR

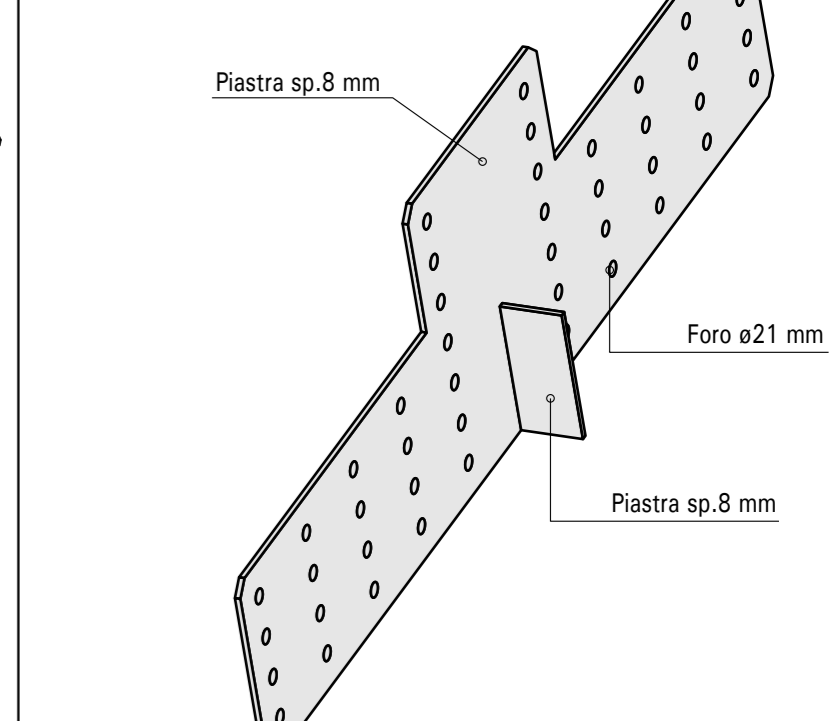

A6-SX		
Q.TA' 8	ZINCATO	S275JR

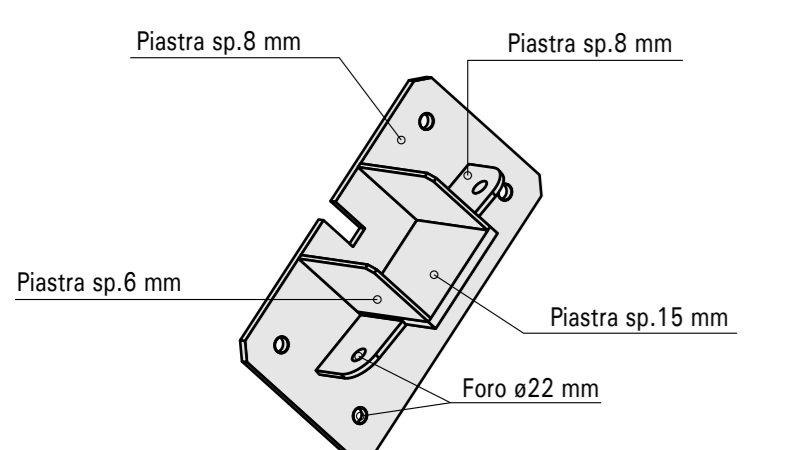

A6-DX		
Q.TA' 8	ZINCATO	S275JR

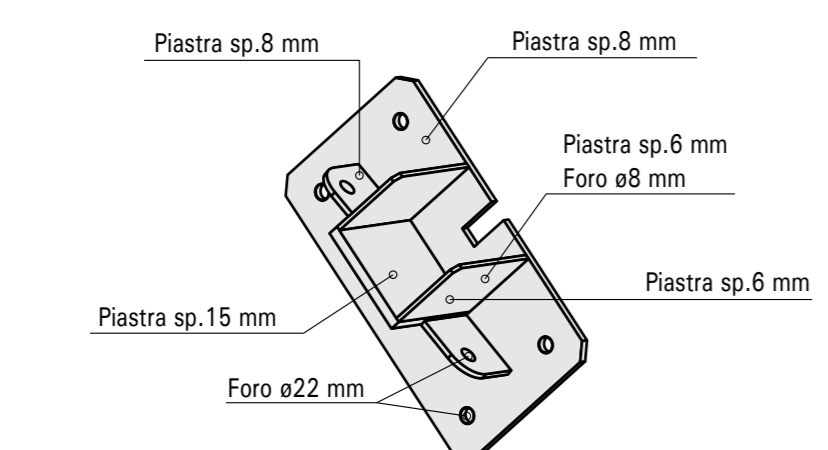

A7-SX		
Q.TA' 8	ZINCATO	S275JR

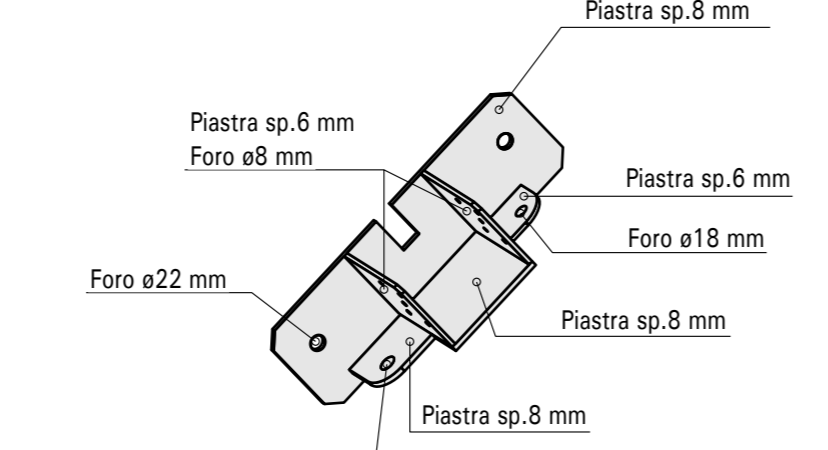

A7-DX		
Q.TA' 8	ZINCATO	S275JR

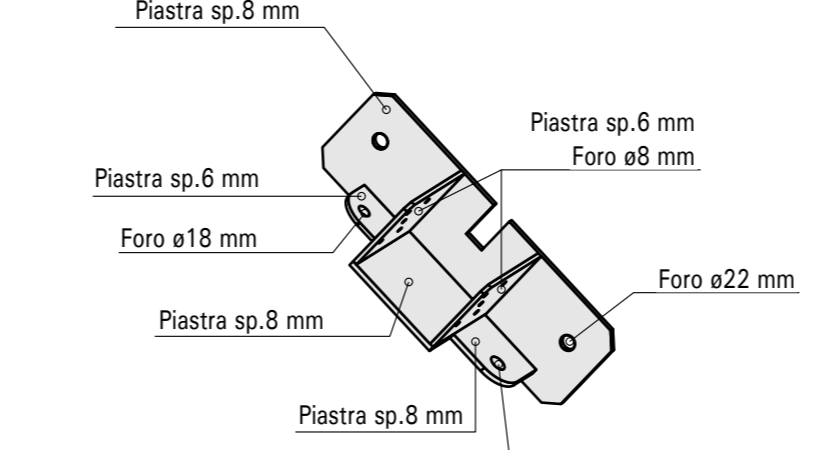

A8		
Q.TA' 88	ZINCATO	S275JR

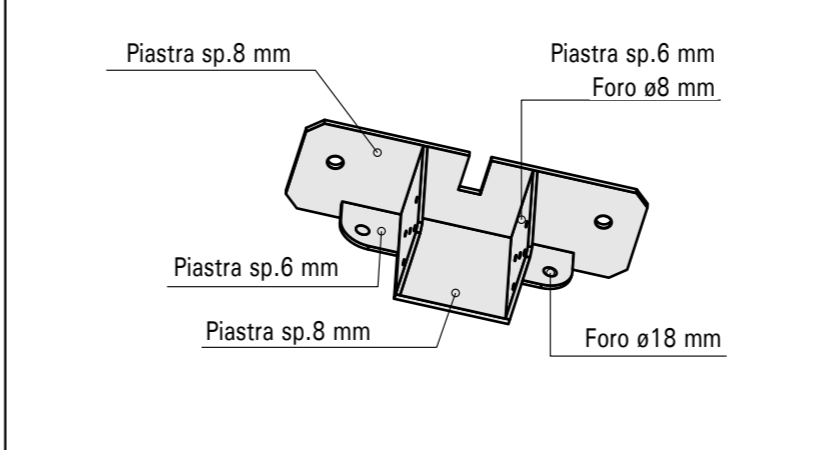

A9		
Q.TA' 4	ZINCATO	S275JR

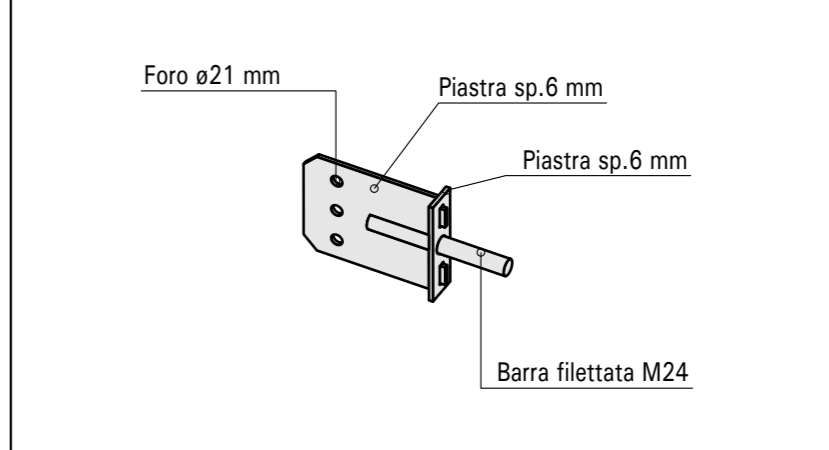

B1		
Q.TA' 6	ZINCATO	S275JR

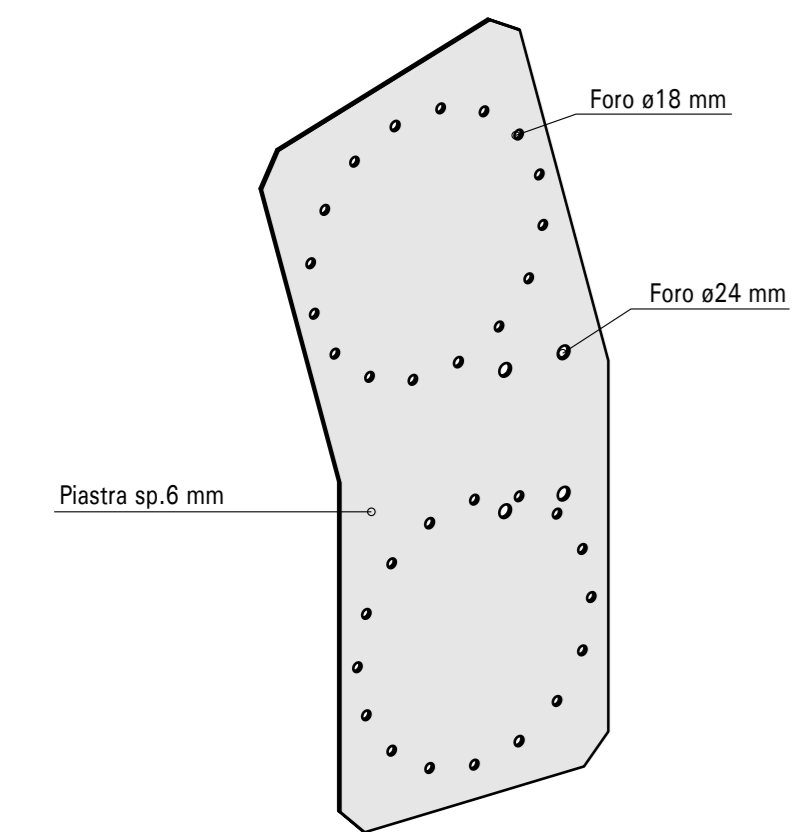

B2		
Q.TA' 4	ZINCATO	S275JR

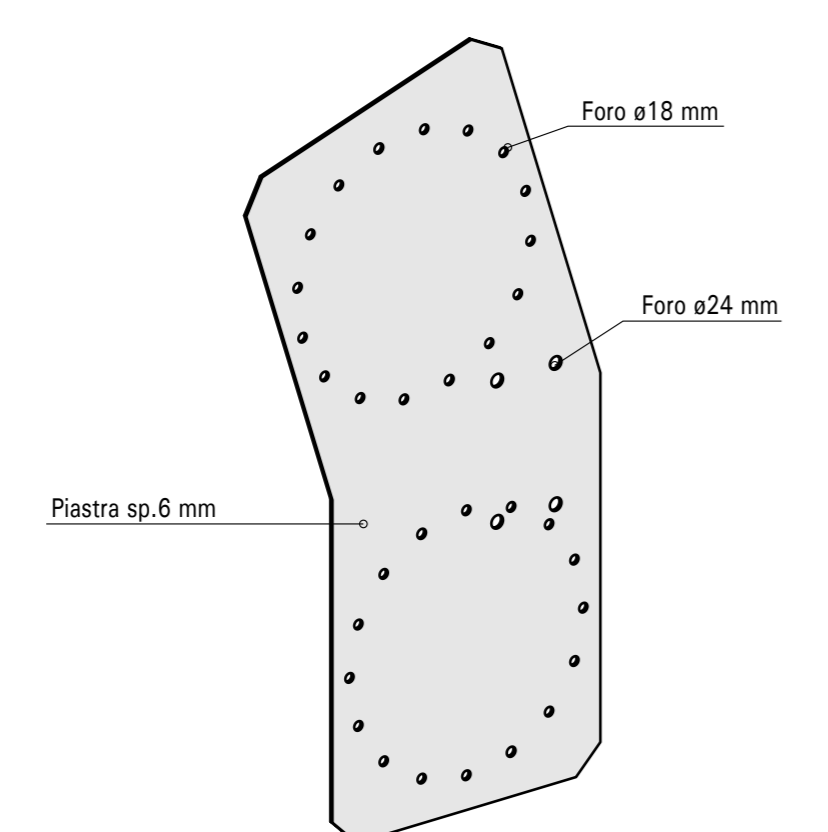

B3		
Q.TA' 4	ZINCATO	S275JR

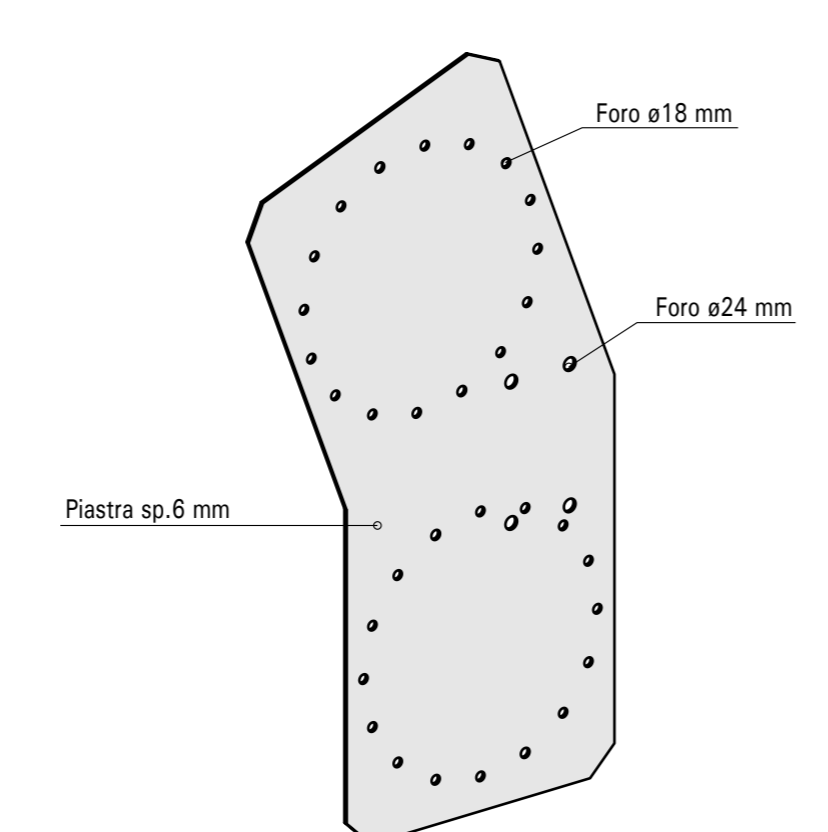

B4		
Q.TA' 4	ZINCATO	S275JR

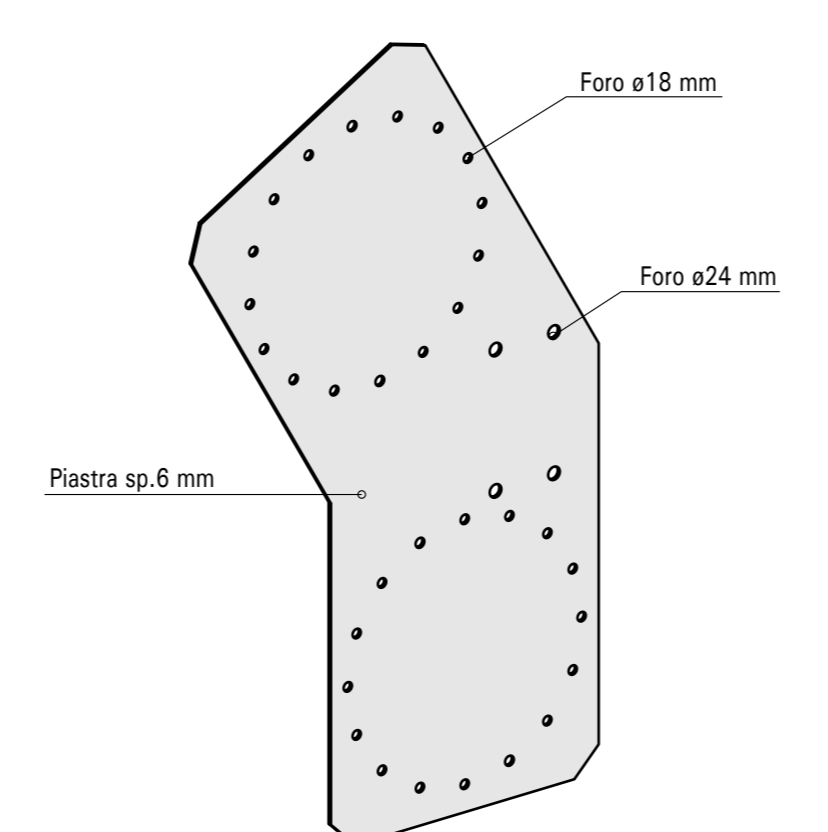

B5		
Q.TA' 18	ZINCATO	S275JR

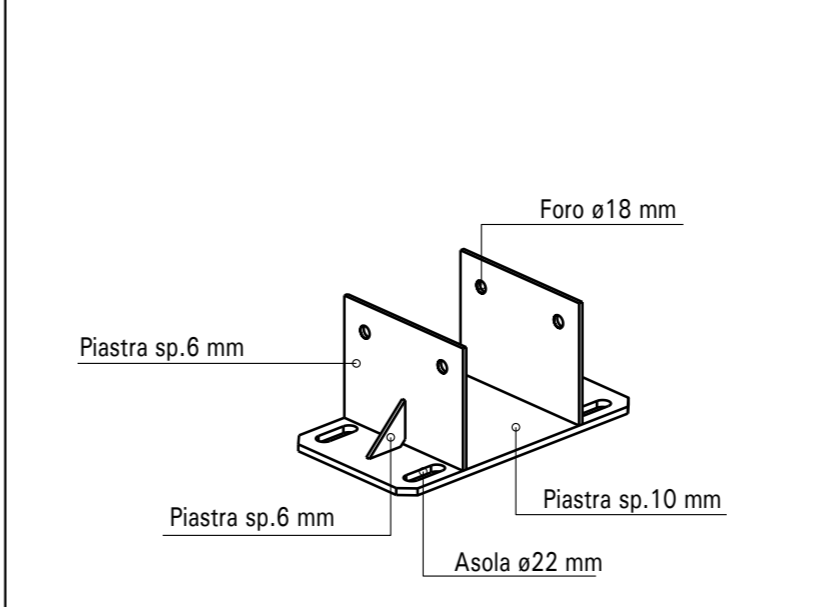

B6		
Q.TA' 14	ZINCATO	S275JR

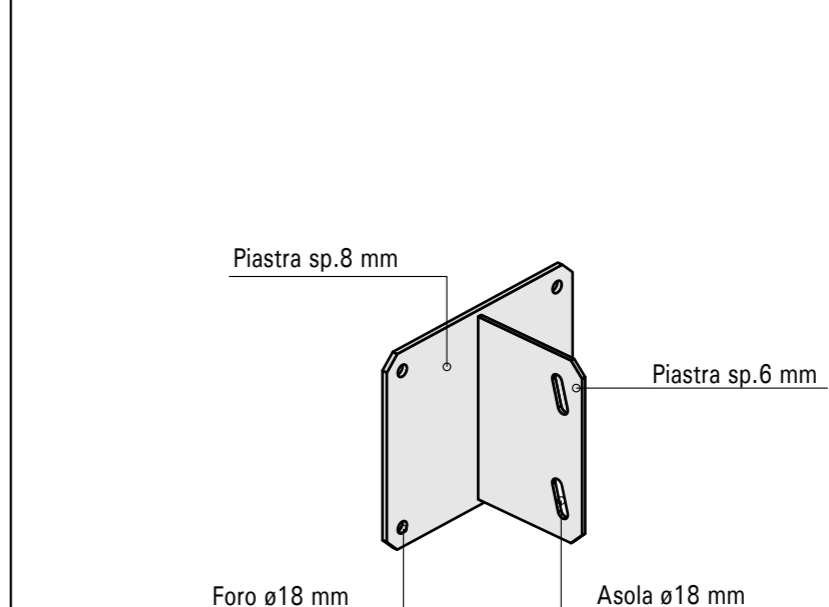

B7		
Q.TA' 4	ZINCATO	S275JR

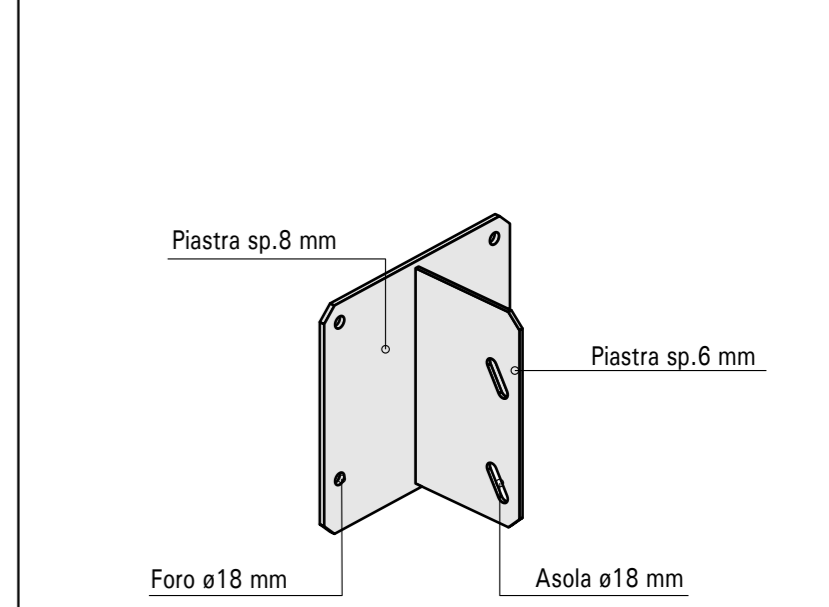

B8		
Q.TA' 64	ZINCATO	S275JR

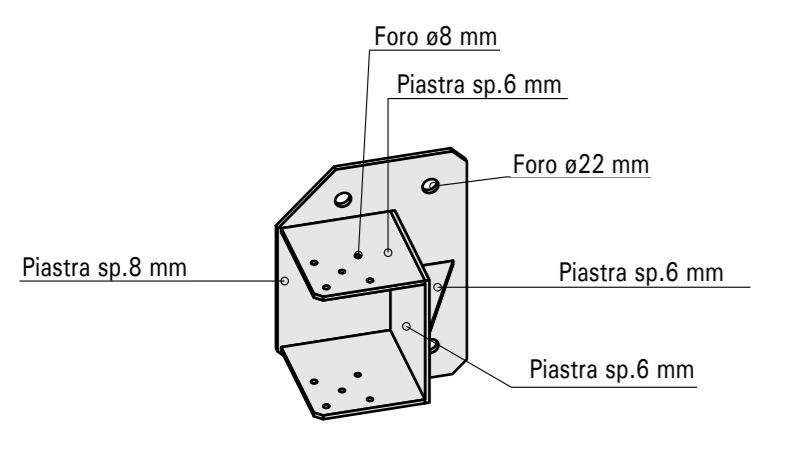

B9		
Q.TA' 3	ZINCATO	S275JR

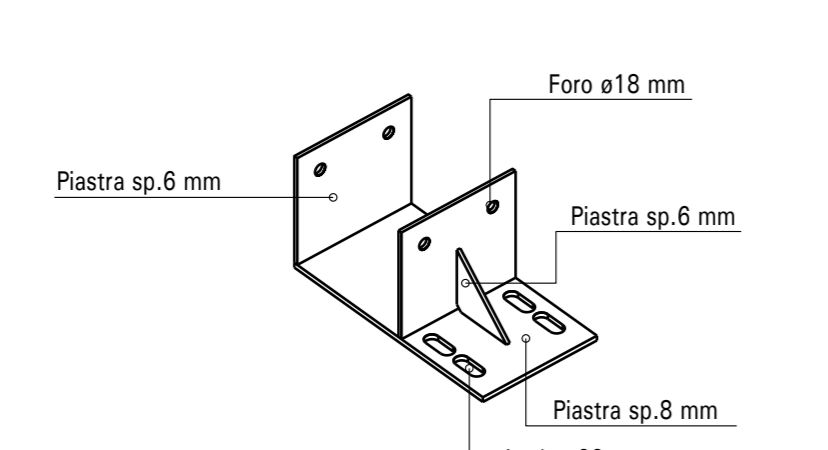

B9-A		
Q.TA' 1	ZINCATO	S275JR

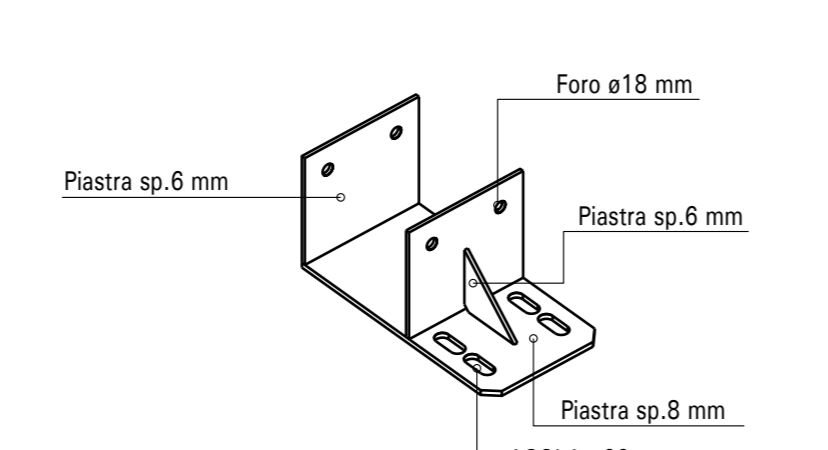

B10		
Q.TA' 8	ZINCATO	S275JR

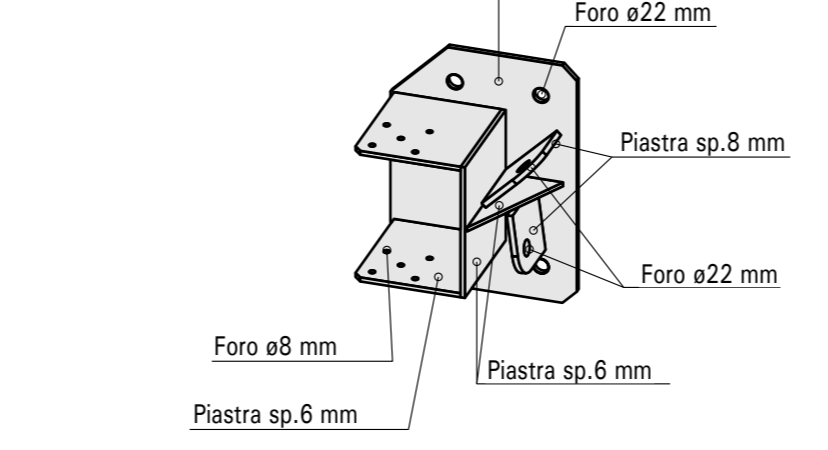

B11		
Q.TA' 8	ZINCATO	S275JR

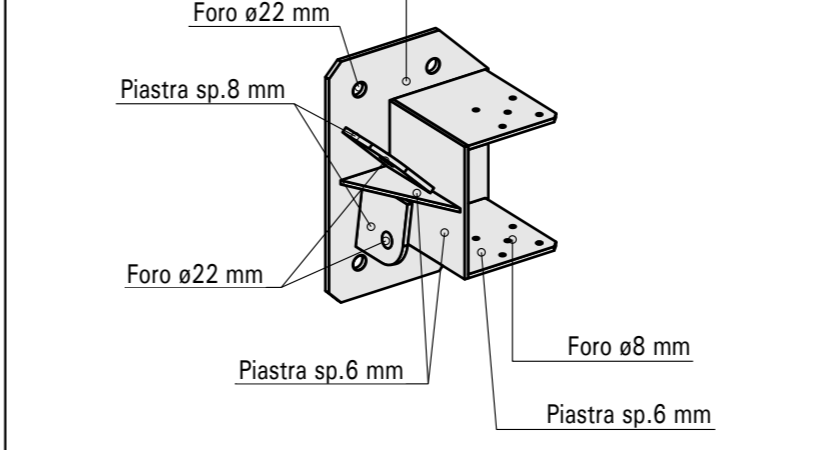

		Holz Albertani S.p.A. Legno lamellare made in Italy	
		Stabilimento: 43012 FONTANELLATO (PR) Località Albareto, 128/B Tel. 0521/823985 - Fax 0521/824920	
TATTAMENTO SUPERFICI METALLICHE	COMMITTENTE	OPERAZIONE	DATA
-	Spett.le	ALLODI S.R.L.	18.07.2023
COLORE IMPREGNANTE STRUTTURA	OPERAZIONE	AREA EX CRAL BORMIOLI (PR)	SCALE
-	SOGETTO	ABACO ATTACCHI	varie
COLORE IMPREGNANTE PERL'INARZO	OPERAZIONE		DISEGNATORE
-	OPERAZIONE		Dem
	OPERAZIONE		TAVOLA N°
	OPERAZIONE		6
CIG 7997127DF5	N° COMMESSA	AGGIORNAMENTO 1	AGGIORNAMENTO 2
CUP I97D18000000001	H2247	18.09.2023	02.10.2023
		AGGIORNAMENTO 3	AGGIORNAMENTO 4
		17.10.2023	
- La società si riserva di apportare modifiche esecutive non sostanziali, imposte dalla evoluzione tecnologica del settore e/o da proprie esigenze, senza obbligo di preavviso.		- A norma di legge sono vietate la riproduzione e la diffusione di tutto o parte del presente elaborato grafico.	
		PROTOCOLLO	
		A 1205	